

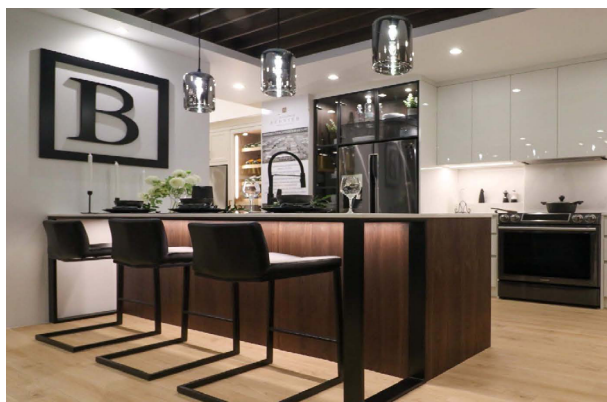

Extrusion

LS-EXT-SUR-16*13

Extrusion de surface pour comptoir, ligne décorative, coup de pied et plus. Sa lentille diffuse parfaitement la lumière. Fait au Québec - Canada.

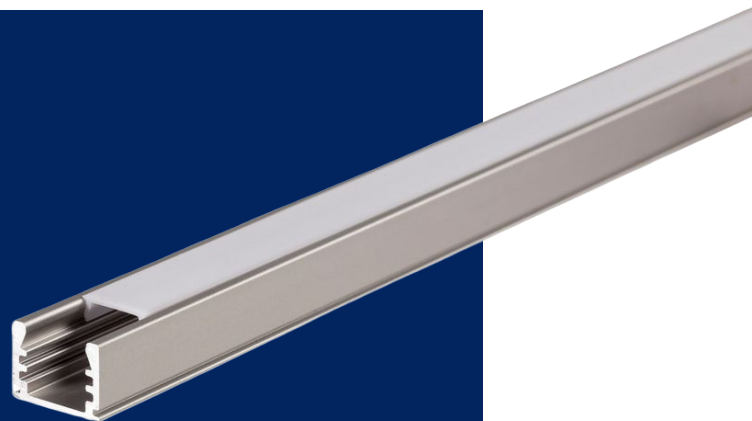

DESCRIPTION

Extrusion pour montage en surface

Très versatile et aluminium robuste (AL6063-T5)

Choix de lentille claire, opaline, givrée ou fumée

Finitions en aluminium naturel, noir ou blanc disponibles
- «Sur mesure» possible sur demande

Compatible avec ruban 10mm

DIMENSIONS



TABLEAU DE COMMANDE - EXTRUSIONS

1 EXTRUSION	2 RUBAN	3 CRI	4 CCT	5 LONGUEUR	6 UNITÉ	7 LENTILLE*
LS-EXT-SUR-16*13						

8 FINI*	9 PROTECTION	10 APPLICATION

11 DEMANDE SPÉCIALE** Exemple : Quantité xx CLIP, Fil alimentation 4 pieds, etc...

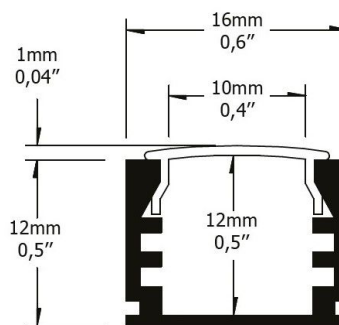
<p>Légende</p> <p>Référez-vous au chiffre correspondant de la case pour les informations à indiquer.</p>	<p>2</p> <ul style="list-style-type: none"> • 12V-400LM • 12V-RGBW • 24V-300LM • 24V-400LM • 24V-600LM • 24V-800LM • 24V-HP • 24V-LL • 24V-RGBW 	<p>3</p> <ul style="list-style-type: none"> • 80 • 90 	<p>4</p> <ul style="list-style-type: none"> • 2700k • 3000k • 3500k • 4000k • 5000k • RGBW • Sur Demande 	<p>5</p> <p>Indiquer longueur souhaitée.</p>	<p>6</p> <p>Indiquer l'unité de mesure de la longueur indiquée :</p> <ul style="list-style-type: none"> • Mètres • Pouces • Pieds 	<p>7</p> <ul style="list-style-type: none"> • CL: claire • Gl: givrée • OP: opaline • SM: fumée • Aucune <p>* Disponibilité à valider</p>
<p>8</p> <ul style="list-style-type: none"> • ALU: aluminium • WHT: blanc • BLK: noir • CTM: custom <p>* Disponibilité à valider</p>	<p>9</p> <ul style="list-style-type: none"> • IP20 • IP65 	<p>10</p> <ul style="list-style-type: none"> • AID: intérieur sec • AIW: intérieur humide 	<p>11</p> <p>Indiquer toute autre information requise pour préciser votre commande.</p>			

*DISPONIBILITÉ À CONFIRMER / **FIL D'ALIMENTATION 24" STANDARD

RUBAN POPULAIRES

Pour plus d'options



MODÈLE

RUBAN

DIMENSIONS

LS-STRIP-24V-400LM

Ruban de 24 volts, avec 400 lumen par pieds

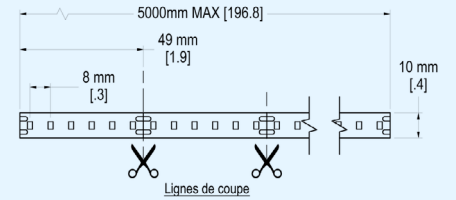

LS-STRIP-24V-600LM

Ruban de 24 volts, avec 600 lumen par pieds

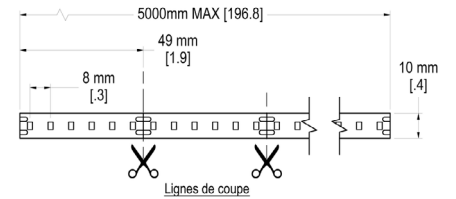

LS-STRIP-24V-800LM

Ruban de 24 volts, avec 800 lumen par pieds

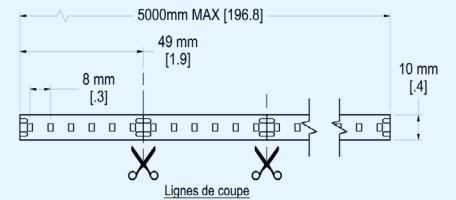

LS-STRIP-24V-RGBW

Ruban de 24 volts RGBW

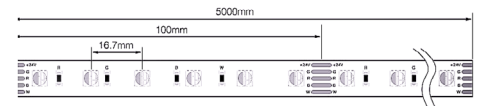

ACCESSOIRES

Pour plus
d'options



MODÈLE

LS-EXT-SUR-16*13-LENS-OPALINE

LS-EXT-SUR-16*13-LENS-GIVRÉE

LS-EXT-SUR-16*13-LENS-CLAIRE

LS-EXT-SUR-16*13-LENS-FUMÉE

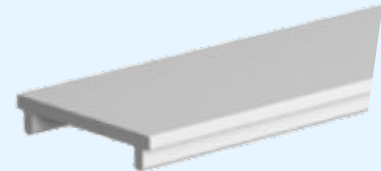

LS-EXT-SUR-16*13-CLIP



LS-EXT-SUR-16*13-END CAP

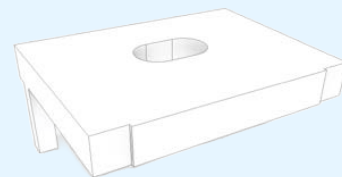

Why | Pourquoi

BOREALUX

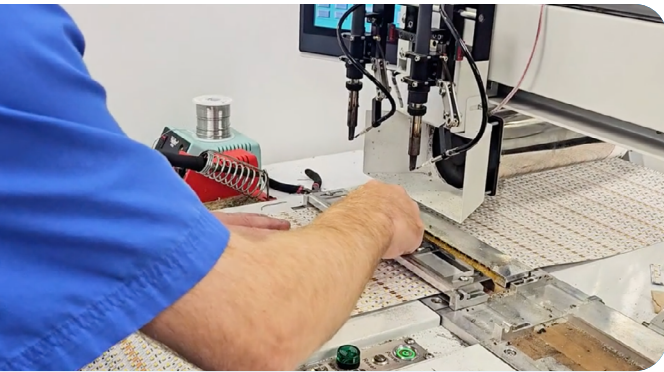

- ✓ 100% Canadian LED manufacturer
- ✓ 5 year warranties
- ✓ Very fast delivery
- ✓ Very high custom production capacity

- ✓ Manufacturier DEL 100 % Canadien
- ✓ Garanties de 5 ans
- ✓ Livraison très rapide
- ✓ Capacité très élevée de production sur mesure

Contact Us Contactez-nous

- ☎ 1-888-540-4713
- ✉ vi@borealux.com
- 📍 670 rue Bouvier, Suite 108,
Quebec, Canada G2J 1A7

BOREALUX.COM



Discover all our products | Découvrez tous nos produits